

# LW-Series

## LW-Series

### WIPER/WASHER CONTROLS

---

The LW-Series Electronic Wiper Washer Control combines two switches into one self-contained unit allowing effortless control of both wash and wipe functions from a singular location. A variety of features and options including, Continuous low and high speed wiper positions, Six intermittent delay intervals ranging from 3-18 seconds, Push-to-wash button and an LED Night-light indicator combine to provide the flexibility to meet most any Cab design. The LW-Series is available for 14 or 28 volt operation and can be adapted to single or dual relay systems.



#### Product Highlights:

- Controls both wash and wipe functions of vehicles
- 14 or 28 Volts
- Illuminated or Non-illuminated options
- Laser etched legends available

#### Typical Applications:

- On/Off-Highway Equipment
- Agricultural Equipment
- Construction Equipment



### Electrical

Contact Rating	1 relay 8 amps, 14VDC 4 amps, 28VDC 2 relays 1 amps, 14VDC 1 amps, 28VDC
Terminals	.187 (7.4mm) Quick Connect terminations standard.
Protection	Reverse polarity protection Over voltage protection Cold cranking protection according to SAE J1455, Sections. 4.11.1.1.1 and 4.11.1.2.1 Transient voltage protection which includes load dump and inductive switching according to SAE J1455, sec. 4.11.2.2 Electrostatic discharge protection according to SAE J1455 Sec. 4.11.2.2.5.1 (Discharge a 150 pf capacitor that has been charged to a potential of 15kV through 150 Ohm resistor.) Meets all other EMI/EMC requirements for class C trucks.

### Mechanical

Mechanical Vibration	Sinusoidal Vibration: 10-55-10 Hz, 0.06" DA, one minute-cycle, three hours/axis Random Vibration: Three hours/axis, three mutually perpendicular axes with a test level 4G's. <b>Frequency      Amplitude</b> 5Hz                0.16 G2/Hz 100Hz            0.16 G2/Hz 500Hz            -3dB/octave roll-off Tests were conducted according to SAE J1455, Sec 5.7 and Sec. 4.9.4. Shock: MIL-STD-202G Method 213B, Test Condition K, 30G's, 11 ms.
Endurance	According to SAE J2349, March 97 for windshield washer switch for Trucks, Buses and Multipurpose Vehicles (20,000 cycle minimum).

### Physical Characteristics

Illumination	LED, rated 100,000 hours 1/2 life
Cover	Acetate
Washer Actuator	Silicone
Toggle Actuator	Nylon 6/6 glass filled
Bracket	Nylon 6/6
Connector	Nylon 6/6 rated 85°C polarized
Washer Function	Momentary
Toggle Function	Maintained Intermittent
Operation	Momentary
Weight	44 grams

### Environmental

Operating Temperature	-25°C to +85°C
Temperature Cycle	According to SAE J1455, Sec. 4.1.3.1 (See Figure below)

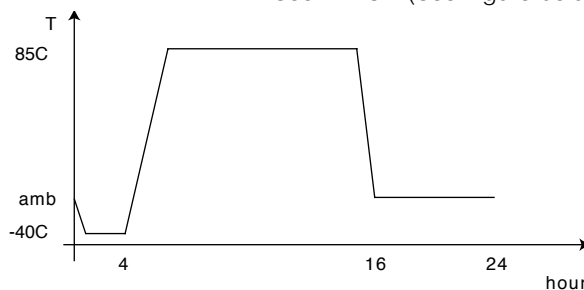

Thermal Shock	According to SAE J1455, Sec. 4.1.3.2 (See Figure below)
---------------	---------------------------------------------------------

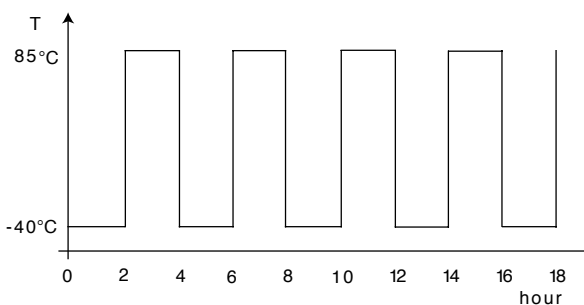

Humidity	According to SAE J1455, Sec. 4.2.3 (30 cycles for 8 hrs. with maximum temperature of 85°C and 95% relative humidity.
Dust Bombardment	According to SAE J1455, Sec. 4.7.3 (with dust concentration of 0.88gm/m for 24 hours.)
Salt Spray	MIL-STD-202G, Method 101D for 96 hours.

\*Manufacturer reserves the right to change product specification without prior notice.

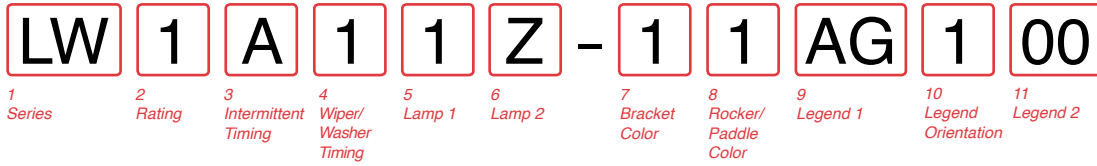

**1 SERIES**  
**LW** Wiper/Washer Control with six intermittent positions:  
 low, high, wash/wipe

**2 RATING 1**

1	8A, 14VDC (1 relay)	4	1A, 14VDC (1 relay)
2	4A, 28VDC (1 relay)	5	1A, 14VDC (2 relay)
3	1A, 14VDC (1 relay)	6	1A, 28VDC (2 relay)

**3 INTERMITTENT TIMING**  
**A** 2-15 seconds

**4 WIPER/WASHER TIMING**  
**1** 3 seconds

**5 LAMP #1 (ABOVE WASH)**

Z	No Lamp	2	Red LED
1	Green LED	3	Amber LED

**6 LAMP #2 (ABOVE WIPE)**

Z	No Lamp	2	Red LED
1	Green LED	3	Amber LED

**7 BRACKET COLOR**  
**1** Black

**8 ROCKER / PADDLE COLOR**  
**1** Black

**9 LEGEND #1**  
**00** No legend  
 For legend options, visit us at [carlingtech.com](http://carlingtech.com)

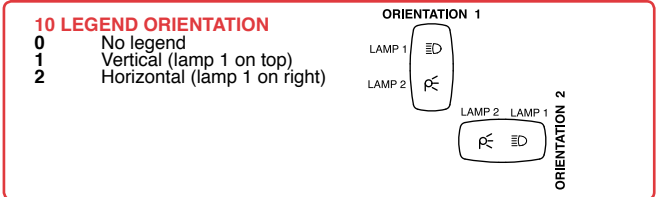

**11 LEGEND #2**  
**00** No legend  
 For legend options, visit us at [carlingtech.com](http://carlingtech.com)

Notes:  
 1 Relay coil current is 1A max. Relay must have an arc suppression in parallel with the coil. Ref P/N LC2-01 for black wiper/washer connector housing.

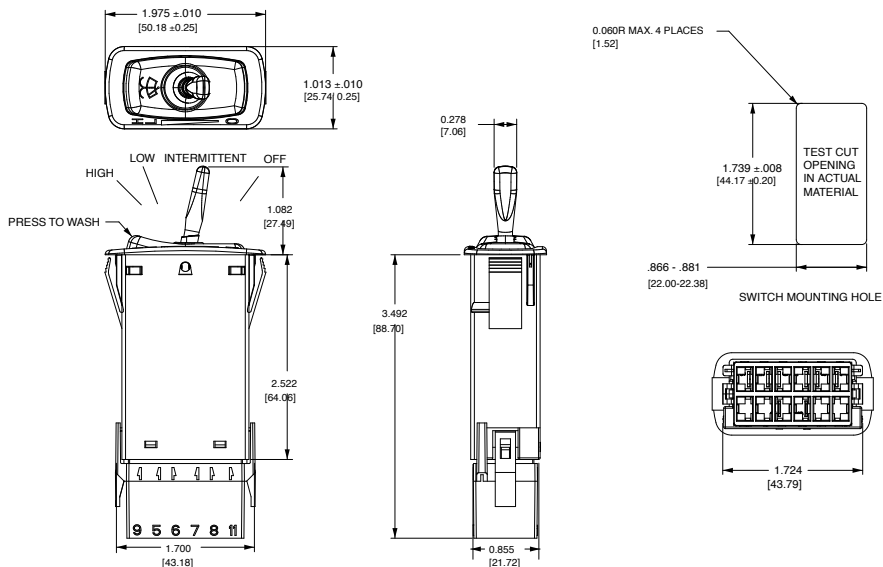

**Principles of operation:**

From the OFF position, moving the toggle one step up puts the function into the intermittent slower mode (18 sec.). Moving the toggle another step up reduces the delay time by 3 sec for each of the next six steps. The seventh step up puts the motor into a continuous low-speed mode and the last step up puts the motor into the high-speed mode. Reversing the previous steps puts the motor finally into the stop/parking mode. During the OFF position, intermittent and low-speed modes, pressing the wash button activates the wash function. Wipe function starts after a two second delay from the onset of the washing and continues for three continuous wipes after the wash button is released. For convenience, the wash function is not active during the high-speed mode.

The Wiper Control is designed to interface with single or dual relay systems for intermittent delay and the park function. The high speed is driven directly via a power transistor internal to the module. The coil of the relay is pulled down to ground during the intermittent, low-speed and high-speed modes respectively. (Contact Carling Technologies for wiring diagrams)